

Preface

JS500 Series Construction Elevator All-in-One Device is an all-in-one lift motor drive featured high-performance vector and torque regulation. The motor drive of this series uses the international leading technologies of sensor-less speed vector control and torque regulation, which not only has an excellent control ability same as the international high-end motor drives but also enhances the reliability, environmental adaptability, and humanized design of the product based on the product application in China and users' need. The all-in-one regulation function of this series' products greatly meets the special need of elevator industry.

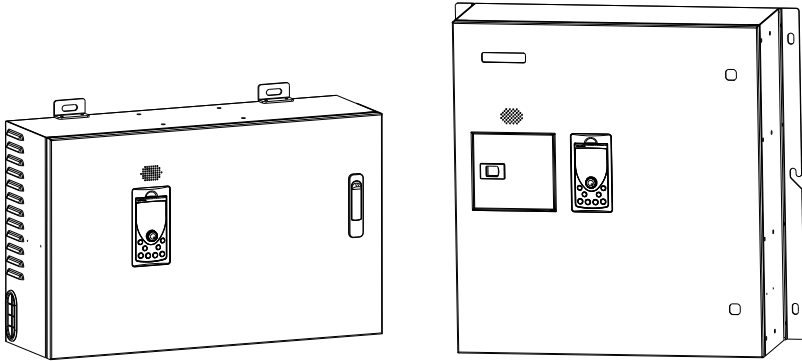

Notices

- To better demonstrate the details of this product, some figures might illustrate the product without its housing or cover plate. When using it, please make sure the housing or cover plate is properly installed on the device and operate under manual instruction.
- The figures are for reference only. They might be different from your purchased product.
- Our company strives to keep improving the products and upgrading their functions. We apologize if there are any changes in this manual.
- Please contact our regional agents or customer service center if you have any questions or issues.

Customer Service: 0510-85380261

Fax: 0510-85380361

24-Hour Tech Support: 13306170378 13306170877

Safety Instructions

Safety Label Notes:

 **Danger:** **Danger** indicates a hazard with a high level of risk which, if not avoided, will result in fire accident, serious injury or death.

 **Caution:** **Caution** indicates a hazard with a low level of risk which, if not avoided, could result in minor or moderate injury and device damage.

■ **Uses**

 Danger
<ul style="list-style-type: none"> ● The product is provided for use in control of the speed of induction motor. It is not intended for other use which could result in fire or device damage. ● The product is not intended for medical use. ● The product is manufactured under strict quality management system. Safety measures such as redundancy or bypass circuit have to be established in case of motor malfunction.

■ **Receiving and Inspection**

 Caution
<ul style="list-style-type: none"> ● Device damage or missing parts could result in accidents.

■ **Installation**

 Caution
<ul style="list-style-type: none"> ● Please hold the bottom of product when transporting and installing. Improper handling the product could result in injury or device damage. ● The product is required to be installed on flame retardants such as metals, staying away from flammables and heat. ● Prevent the residues from drilling holes from falling inside the product, which could result device damage. ● Ventilators should be built when installing the product in an electrical cabinet equipped with fans and vents.

■ **Wiring**

 Danger
<ul style="list-style-type: none"> ● Only personnel who is appropriately trained and experienced should wire the product. Inappropriate use might result in electric shock or device damage. ● Be sure to disconnect the power before wiring the product. ● The ground terminals should be properly grounded. Risk of live chassis. ● DO NOT touch the main circuit terminals. The main circuit terminals should not contact the housing. ● Leakage current is greater than 5 mA and should be determined for specific values by use conditions. For safety purpose, the motor and drive should be grounded.

■ **Wiring**

 Caution
<ul style="list-style-type: none"> ● DO NOT connect three-phase power to output terminals U, V, and W, or the product will be damaged. ● Connecting a capacitor or LC/LR filters with phase advance to the drive's output terminals is prohibited since it will cause motor drive's internal parts damage. ● Be sure to check if the phase number of power and rated voltage match the nameplate on the product. ● DO NOT conduct dielectric withstand test on the product. ● The wiring of main circuit terminal and control terminal should be separate or perpendicularly crossed. Otherwise, the controller signal will be interfered. ● Use the insulating cased cable lugs for the wires of main loop terminals. ● Use output reactors when the input and output cables are longer than 100 meters in case of over current generated by excessive distributed capacitance.

■ Operation

 Danger
<ul style="list-style-type: none"> ● Connect the power supply only after the cable distribution is complete and the cover plate is installed. DO NOT remove the cover plate while the power supply is connected. ● Take safety measures when the motor drive sets a auto-reset function or an automatic start-up after power outage. ● After the motor drive is powered on, a charge may still remain on the motor drive’s terminal with hazardous voltage even if it has been turned off. Touching the terminals could result in electric shock. ● Reset faults and send out warning messages only after confirming the run command has been cut off.

■ Operation

 Caution
<ul style="list-style-type: none"> ● DO NOT turn on/turn off the motor drive by connecting/disconnecting the power. Doing so may cause damage or destroy the product. ● Be sure to check if the motor drive is operating within specification before use. Failure to comply may result in device damage. ● The temperature of the radiator and braking resistor could get extremely high. Touching them may result in burns. ● When using the product on a lifting device, please also configure the contracting brake device. ● DO NOT modify parameters on the motor drive since the product operates the best with default parameters and may be damaged from changing them frequently. Modifying necessary parameters is allowed. ● Two contactors for switching between power frequency and variable frequency should interlock in some occasions of switching these frequencies.

■ Maintenance

 Danger
<ul style="list-style-type: none"> ● DO NOT touch the terminals while energized. ● Disconnect power before removing the cover plate. ● Wait at least 10 minutes or the “CHARGE” indicator is turned off before maintenance. Remaining charge with hazardous voltages in the electrolytic capacitors may cause injury. ● Only qualified personnel are to do maintenance, inspection and replacing parts.

 Caution
<ul style="list-style-type: none"> ● There is a large scale integration of CMOS components that are sensitive to static electricity on the circuit board. To prevent static electricity from damaging the circuit, DO NOT touch the components with bare hands

■ Other

 Caution
<ul style="list-style-type: none"> ● Do not modify the motor drive which may cause injury.

Table of Contents

Preface..... - 1 -

Table of Contents - 4 -

Chapter 1 Product Information..... - 5 -

 1.1 Product Model..... - 5 -

 1.2 Product Nameplate - 5 -

 1.3 Product Series..... - 5 -

 1.4 Product Specifications..... - 6 -

 1.5 Product Features..... - 7 -

Chapter 2 Product Machinery and Wiring..... - 8 -

 2.1 Ambient Conditions..... - 8 -

 2.2 Appearances and Dimensions..... - 9 -

 2.3 Wiring Information..... - 10 -

Chapter 3 Keypad Display and Operation..... - 14 -

 3.1 Operation and Display Interface..... - 14 -

 3.2 Keypad Indicators - 14 -

 3.3 Keypad Buttons Explanation..... - 14 -

 3.4 Function Codes Look-up and Modification - 15 -

 3.5 Menu Mode Selection - 15 -

Chapter 4 Parameters - 16 -

 4.1 Function Parameters List..... - 16 -

 4.2 Special Function..... - 21 -

Chapter 5 Maintenance and Troubleshooting..... - 24 -

 5.1 Daily Maintenance and Inspection - 24 -

 5.2 Warranty - 25 -

 5.3 Fault Alarm and Solutions..... - 25 -

 5.4 Common Errors and Solutions - 28 -

Chapter 6 Accessories Model Recommendation - 29 -

 6.1 Braking Resistor Model Recommendation - 29 -

 6.2 Specs and Dimensions of the In-Cage Operation Panel..... - 30 -

 6.3 Specs of Load Pin Sensors - 31 -

 6.4 Rooftop Control Box/Drop Test Box..... - 31 -

 6.5 Model Selection of Encoders and Installation Instructions - 31 -

Appendix A Instruction Manual - 32 -

Appendix B Bolts Tightening Torque..... - 32 -

Chapter 1 Product Information

1.1 Product Model

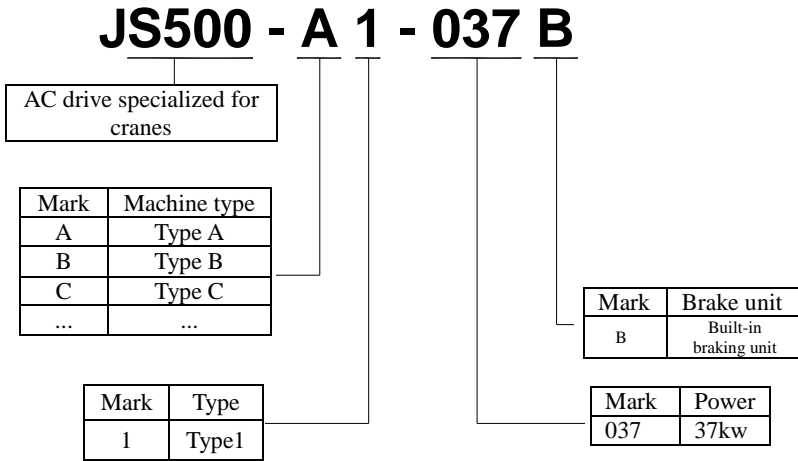

Figure 1-1 Product Model Name

1.2 Product Nameplate

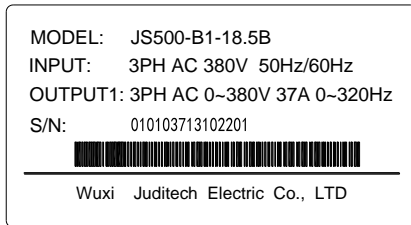

Figure 1-2 Nameplate

1.3 Product Series

Motor Drive Model	Power Supply Capacity kVA	Input Current A	Output Current A
JS500-A1-037B	57	76	75
JS500-B1-037B	57	76	75
JS500-B1-075B	114	157	150

1.4 Product Specifications

Items		Specifications		
Power Supply	Voltage/Frequency	Three Phase 380V 50/60Hz		
	Fluctuation Range	Voltage Unbalance<3% ; Frequency : $\pm 5\%$; Distortion Rate satisfies IEC61800-2		
	Closing Gate Impulse Current	Less than rated current		
	Efficiency	$\geq 96\%$		
Basic Function	Highest Frequency	0~320Hz		
	Carrier Frequency	0.5kHz~16kHz Temperature-controlled adjustment of carrier frequency		
	Input Frequency Resolution	Digital Setting: 0.01Hz Simulated Setting: Highest Frequency $\times 0.025\%$		
	Control Methods	Open-Loop Vector Control (SVC) 1 Open-Loop Vector Control (SVC) 2 Closed-Loop Vector Control (FVC)		
	Start-Up Torque	Model G: 0.5Hz/150% (SVC) ; 0Hz/180% (FVC) Model P: 0.5Hz/100%		
	Speed Range	1: 100 (SVC)	1: 1000 (FVC)	
	Steady Speed Precision	$\pm 0.5\%$ (SVC)	$\pm 0.02\%$ (FVC)	
	Torque Control Accuracy	$\pm 5\%$ (FVC)		
	Overload Capacity	Model G: 150% Rated Current 60s; 180% Rated Current 3s Model P: 120% Rated Current 60s; 150% Rated Current 3s		
	Torque Magnification	Automatic Torque Magnification ; Manual torque Magnification 0.1%~30.0%		
	Jogging Control	Jogging Frequency Range: 0.00Hz~50.00Hz Jog Acceleration/Deceleration Time : 0.0s~6500.0s		
	Automatic Voltage Regulation (AVR)	Output voltage remains steady automatically when grid voltage changes.		
	Over Current/Over Voltage/Stall Control	To prevent frequent over current, over voltage, and trip, current and voltage are automatically limited		
	Quick Current Limiting Function	Minimize errors caused by over current to protect the motor drive.		
Torque Limit and Control	Automatically limit the torque while like “an excavator” running to prevent frequent over current and trip; Closed loop vector mode can realize torque control.			
Keypad and Display	LED Display	Display Parameters(Three Display Modes: Default Mode, Quick Menu Mode, and Non-Factory Value Mode)		
	Fault Alarm	Motor Short Detection, Input/Output Phase-Loss Protection, Over-Current Protection, Over-Voltage Protection, Under-Voltage Protection, Overheat Protection, Overload Protection, Contracting Brake Related Protection, and Position Protection, etc.		
	Status Monitoring	Refer to H0 parameters.		
Environment	Ambient Requirement	Keep it indoor; Avoid direct sunlight; No dust, corrosive gas, flammable gas, oil, mist, steam, water drops, and salt, etc; Atmospheric Pressure: 70~106kPa.		
	Altitude	Use below 1000m; Derate above 1000m; Rated output current decreases by 1% per 100m.		
	Ambient Temperature/Humidity	-10℃~+50℃, <95%RH, No condensation.		
	Vibration	<5.9m/s ² (0.6g)		

	Storage Temperature	-20℃~+60℃
	Installation	Mounting, Cabinet
	IP Level	IP23
	Cooling	Force Air

1.5 Product Features

1. GPS/GPRS real-time data monitor greatly minimize the fuss during troubleshooting and after-sales service.
2. Protection Function: Other than basic protection functions, the motor drive is also equipped with functions such as braking resistors, power control protection, position protection, and torque output detection.
3. Automatic leveling control reduces the difficulty of operation.
4. Input Terminal Logic-Safe Monitor: Real-time monitoring the logical order in case of false input.
5. Improved Structure Design: Use the integrated bridge rectifiers with SCR, making the device’s heating dissipation and power design more reasonable.
6. Voice Prompt: Our product features the voice prompt function, which supports two languages, Chinese and English.
7. Equipped with the contracting brake logic, shown as below:

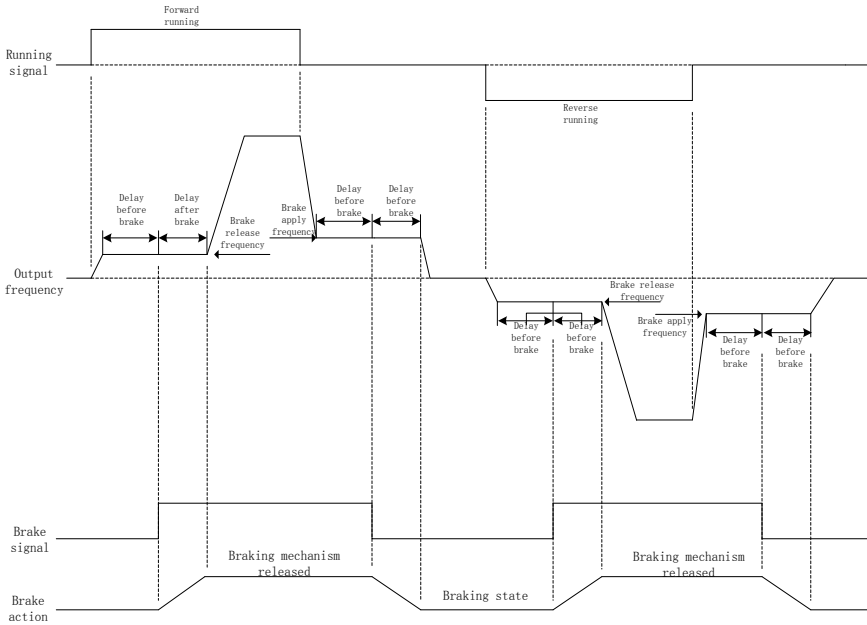

Chapter 2 Product Machinery and Wiring

2.1 Ambient Conditions

1. Ambient Temperature: The temperature affects the life of motor drive. It is prohibited to run the motor drive out of ambient temperature range (-10°C~50°C).
2. Please install motor drive on flame retardants and mount it vertically on mounting brackets using bolts or screws. Be sure to allow sufficient space around the motor drive for heat dissipation since it generates heat while running.
3. Please install the motor drive on a flat surface where the vibration should remain lower than 0.6g, away from punches, etc.
4. Avoid installing the motor drive under direct sunlight or in humid places.
5. Avoid installing the motor drive in places of corrosive, flammable and explosive gas.
6. Avoid installing the motor drive in places full of oil, dust and metal particles.

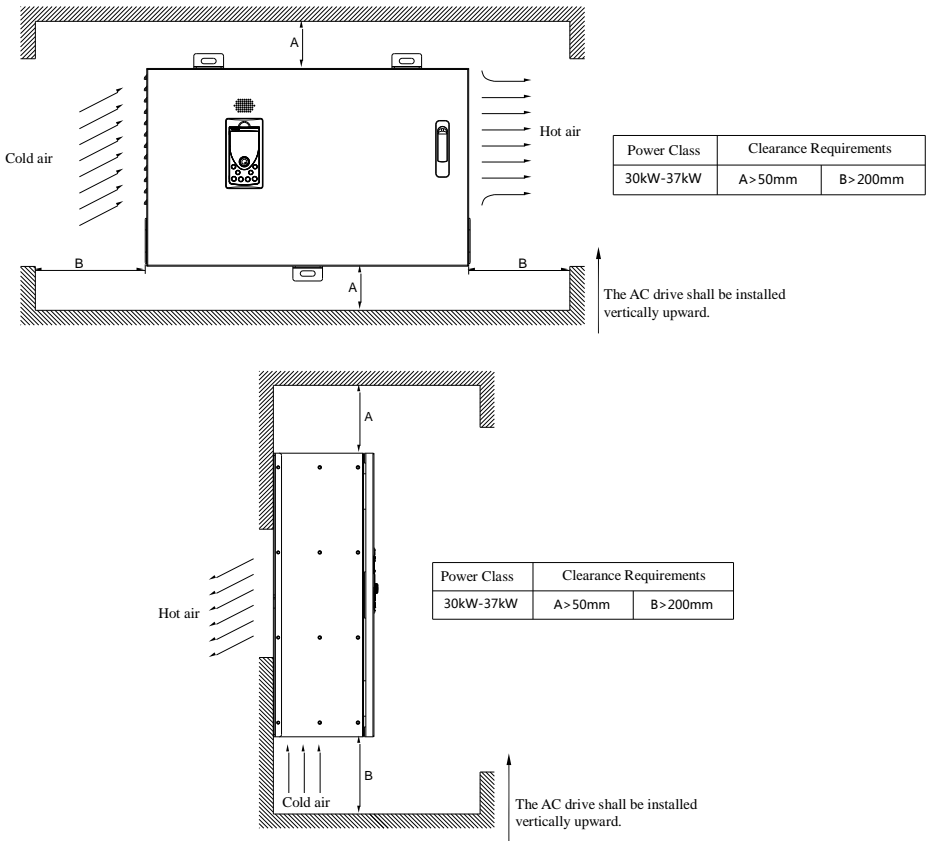

Figure 2-1 Installation of JS500 Series Motor Drive

2.2 Appearances and Dimensions

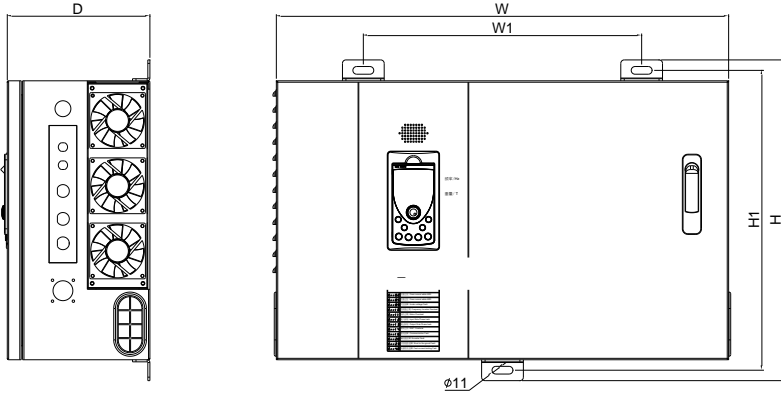

Figure 2-2 JS500-A1 Dimensions

Model	Mounting Holes		Dimensions			Diameter of Aperture For Installation
	W1	H1	H	W	D	
JS500-A1-037B	400	430	460	655	205	Φ11

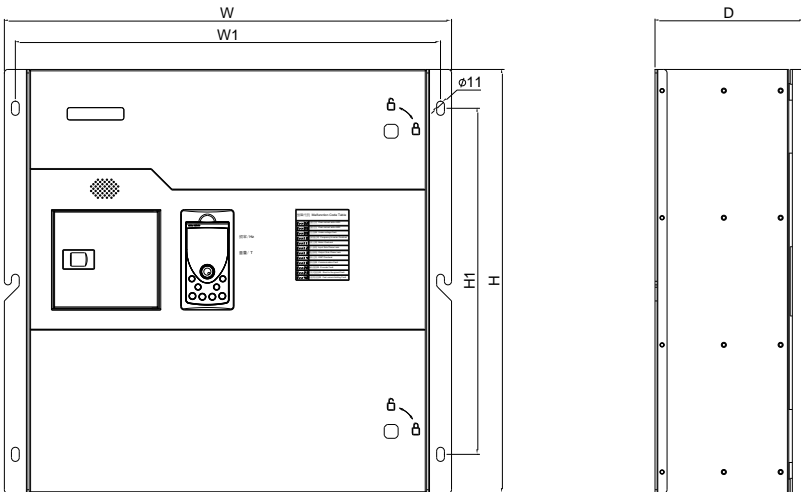
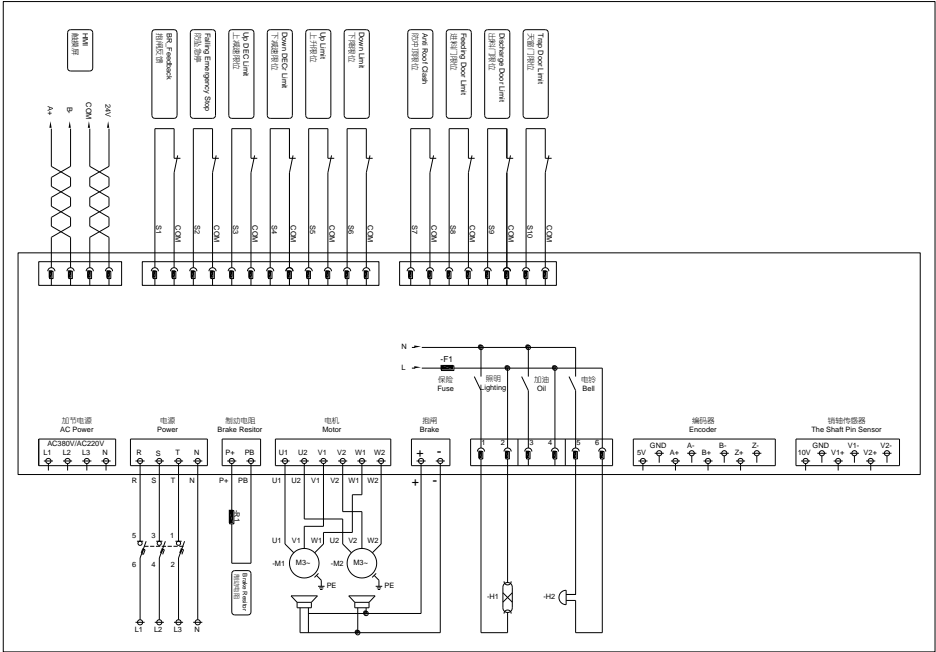

Figure 2-3 JS500-B1 Dimensions

Model	Mounting Holes		Dimensions			Diameter of Aperture For Installation
	W1	H1	H	W	D	
JS500-B1-037B	599	490	600	630	210	Φ11

2.3 Wiring Information

2.3.1 Wiring Diagram



2.3.2 Wiring Diagram For Driver's Operation Platform

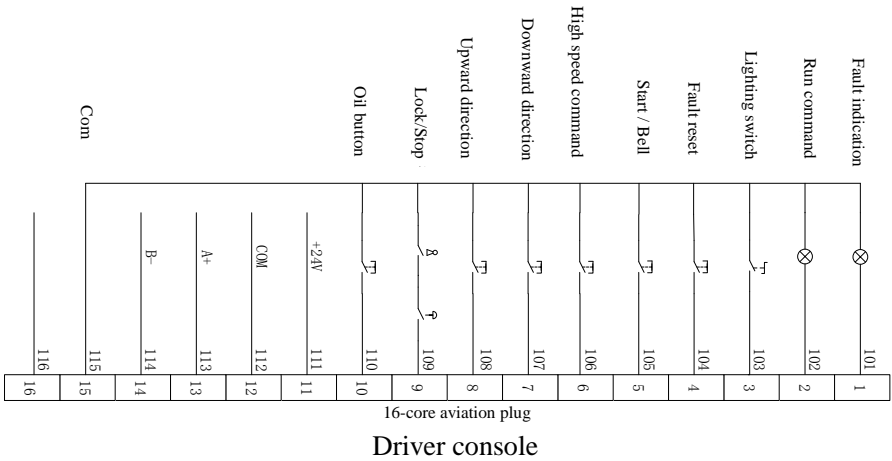

2.3.3 Aviation Plugs Wiring Information

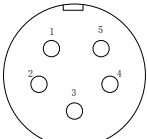
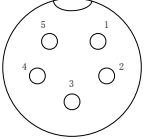
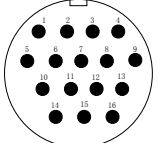
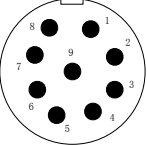
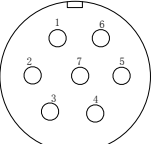
Aviation Plugs	Pin Number	Pin Definition	Aviation Plugs	Pin Number	Pin Definition
 <p>Drop test socket</p>	1	COM	 <p>Pin sensor socket</p>	1	Power(+)
	2	Empty		2	Sensor Signal(-)
	3	Rise Test		3	PE
	4	Empty		4	Power(-)
	5	Drop Test		5	Sensor Signal(+)
Aviation Plugs	Pin Number	Pin Definition	Aviation Plugs	Pin Number	Pin Definition
 <p>Driver console aviation socket</p>	1	In-Cage Error Indicator	 <p>Encoder socket</p>	1	Power Supply(+)
	2	In-Cage Operation Indicator		2	Power Supply(-)
	3	Illumination Switch		3	Encoder A+
	4	In-Cage Reset Button		4	Encoder A-
	5	In-Cage Start/Electric bell button		5	Encoder B+
	6	Master High Speed Signal		6	Encoder B-
	7	Master Down Signal		7	Encoder Z+
	8	Master Up signal		8	Encoder Z-
	9	Electric Lock/Emergency Stop Switch		9	PE
	10	Oiling Signal	 <p>Cage top socket</p>	1	In-Cage/Out-Cage Switch
	11	24V Power Supply		2	COM
	12	COM (Public)		3	Out-Cage Emergency Stop
	13	485 A+		4	Out-Cage Start
	14	485 B-		5	Out-Cage Up
	15	COM(Public)		6	Empty
	16	Empty		7	Out-Cage Down

2.3.4 Peripherals' Input/Output Terminals Definitions

1. Peripherals' Input/Output Terminals Layout:

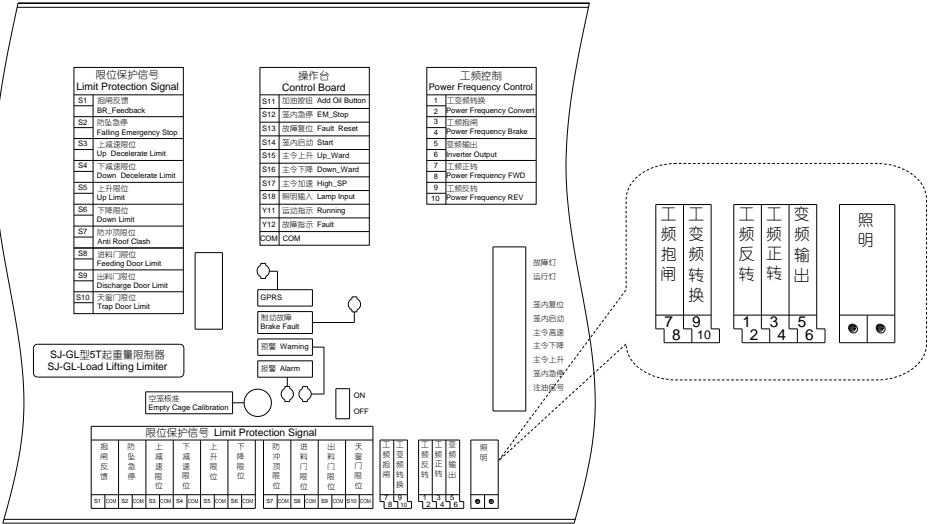

2. Peripherals' Input/Output Terminals Functions

Terminal Name	Terminal Definitions	Terminal Name	Terminal Definitions
1、2	Reversing Contactor of Power Frequency	7、8	Contracting Brake of Power Frequency Switch
3、4	Forward Contactor of Power Frequency	9、10	Take Over/Variable Frequency Switch
5、6	Output Contactor of Variable Frequency	Illumination	External Lights

2.3.5 Main Loop Terminal Arrangement and Definitions



Terminal Symbol	Name	Explanations
N、R、S、T	Three Phase Power Input Terminal	AC input and three phase power junction point
PB、P+	Braking Resistor Connection Terminal	Prevent bus bar voltage from being too high
U1、V1、W1、U2、V2、W2	Motor Drive Output Terminal	To connect the three phase motor (Motor 2 is the main output)
-、+	Contracting Brake Power Terminal	DC contracting output, “+” positive and “-” as negative.
⊕	Ground Terminal	Ground Terminal

2.3.6 Running Signal/Limit Terminal Definition

1) Running Signal/Limit Terminal Layout

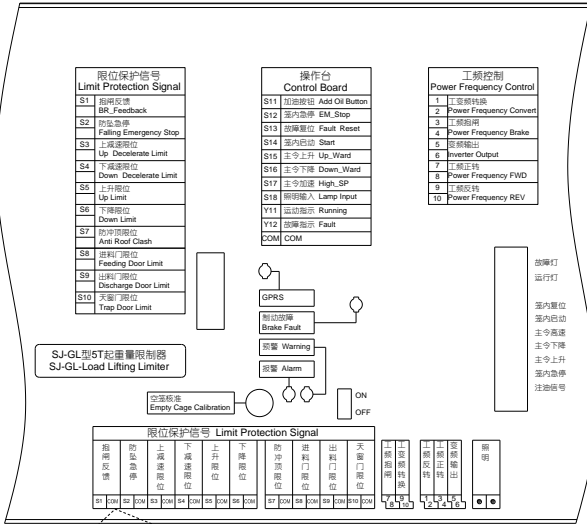

限位保护信号 Limit Protection Signal									
抱闸反馈	防坠急停	上减速限位	下减速限位	上升限位	下降限位	防冲顶限位	进料门限位	出料门限位	天窗门限位
S1	COM	S2	COM	S3	COM	S4	COM	S5	COM
S6	COM	S7	COM	S8	COM	S9	COM	S10	COM

2) Running Signal/Limit Terminal Function

Terminal Name	Terminal Definitions	Terminal Name	Terminal Definitions
S1	Contracting Brake Feedback	S6	Descending Limit
S2	Emergency Stop	S7	Anti-Rush Top Limit
S3	Upward Deceleration Limit	S8	Feed Gate Limit
S4	Downward Deceleration Limit	S9	Discharge Gate Limit
S5	Ascending Limit	S10	Skylight Limit

Chapter 3 Keypad Display and Operation

3.1 Operation and Display Interface

Use the control panel to change the parameters of the motor drive, monitor it and run commands (start, stop, etc) on it. Below is the layout:

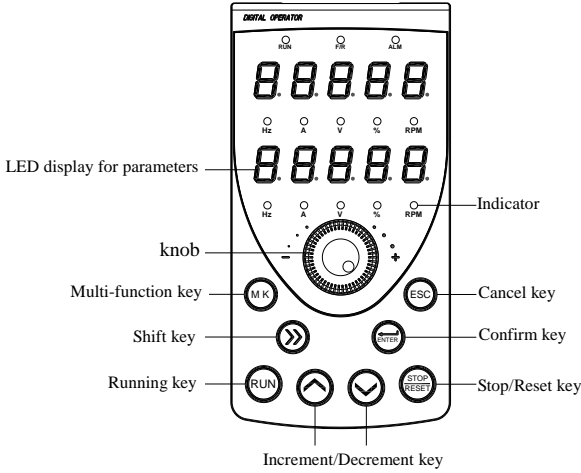

Figure 3-1 Keypad Layout

3.2 Keypad Indicators

- RUN: Running Indicator, indicating device is running;
- ALM: Error/Motor Parameter Identification Indication. Flashing indicates errors detected or running motor parameter identification. If the indicator stays on, it indicates torque control mode;
- Hz: Frequency Unit Indicator, indicating the parameter unit is “Hz”;
- A: Current Unit Indicator, indicating the parameter unit is “A”;
- V : Voltage Unit Indicator, indicating the parameter unit is “V”;
- % : Ratio Unit Indicator, indicating the parameter unit is “%”;
- RPM: Rotating Speed Indicator, indicating the parameter unit is “rpm”;
- F/R: Direction Status Indicator. It indicates reverse direction when it’s on.

3.3 Keypad Buttons Explanation

Button	Name	Functions
ESC	Exit	Enter the primary menu or exit
ENTER	Enter	Enter the next interface; Confirm the setting of parameters
Λ	Increase	Increase the parameter number or function code by one unit
V	Decrease	Decrease the parameter number or function code by one unit
>>	Shift	Choose display parameters on the stopping and running display interfaces; Shift through each unit when changing the parameters.
RUN	Run	Run commands.

STOP/RESET	Stop/Reset	Stop running if the device is working; Reset the device when fault alarm is detected.
MK	Multifunctional Selection	Refer to F8.01 for functions switching.

3.4 Function Codes Look-up and Modification

JS500 series construction elevator all-in-one device’s keypad features three-level menu mode: function parameters group (first level menu), function codes (second level menu), and function codes modification (third level menu). The float chart is shown as below:

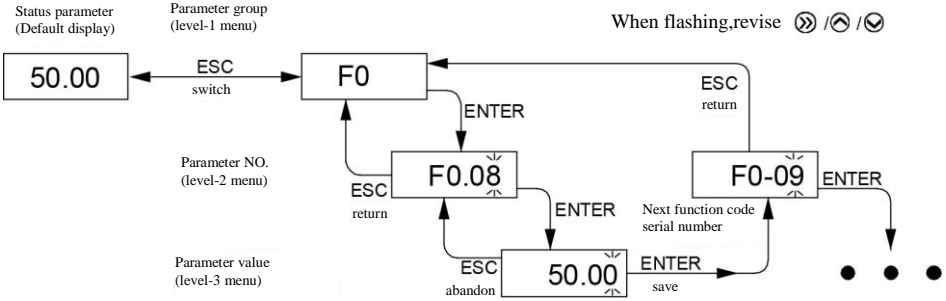

Figure 3-2 Three-Level Menu Float Chart

When changing parameters on the third level menu, you can press “ESC” or “ENTER” to return to the second menu. The difference is that pressing “ENTER” saves the modified parameters while pressing “ESC” does not save them.

E.g. Changing 12 to 22 referring to F2.03 “X4 Terminal Function Selection”:

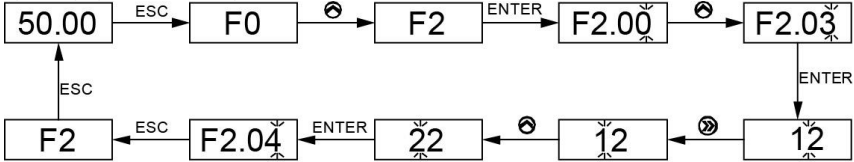

Figure 3-3 Example

3.5 Menu Mode Selection

JS500 series construction elevator all-in-one device offers three menu modes to select from. User may set the corresponding bit of the menu mode he/she needs as “1” according to F0.25 and switch using the button “MK”. Follow figure 3-4 to switch the menus after setting the function parameters.

Note: Only when F8.01 is set to 1, “MK” button selects menu modes.

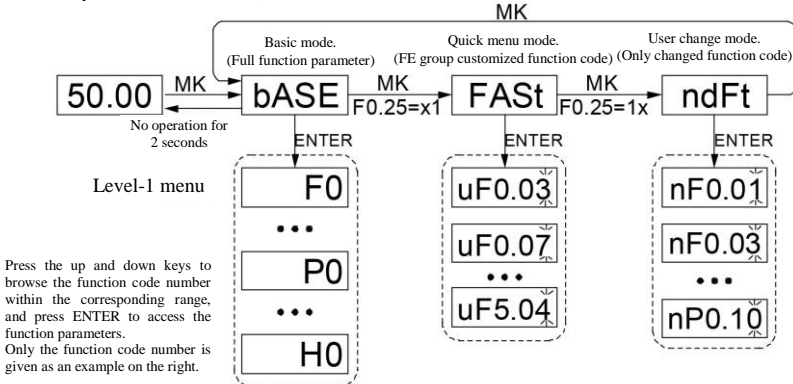

Figure 3-4 Menu Switching

Chapter 4 Parameters

Label Notes:

- “●”: represents the code parameter can be modified while running.
- “○”: represents the code parameter cannot be modified while running.
- “◇”: represents the value of this parameter is the actual value from measuring and cannot be modified.
- “X”: represents “Factory Parameter”, subject to the manufacturer. User’s operation is prohibited.

4.1 Function Parameters List

Function Codes	Code Name	Range of Settings	Factory Value	Property	Setting Value
F0: Basic Function Parameters					
F0.01	Motor Control Methods	0: Speed Sensorless Vector Control1 1: Vector Control With Speed Sensor 2: Speed Sensorless Vector Control2	2	○	
F0.02	Commands Setting Method	0: Keypad Control 1: Terminal Control 2: Communication control	1	●	
F0.10	Maximum Frequency	50.00Hz~320.00Hz	50.00Hz	○	
F0.12	Frequency (Upper Class Limit)	Lower Class Limit Frequency (F0.14) ~Upper Class Limit Frequency (F0.10)	50.00Hz	●	
F0.14	Frequency(Lower Class Limit)	0.00Hz~Upper Class Limit Frequency F0.12	0.00Hz	●	
F0.15	Carrier Frequency	0.5kHz~16.0kHz	4.0kHz	●	
F0.17	Acceleration Time 1	0.0s~6500.0s	6.0s	●	
F0.18	Deceleration Time1	0.0s~6500.0s	2.0s	●	
F0.23	User Password	0~65535	—	●	
F0.24	Parameter Initiation	0: No Operation 1:Factory Parameters Reset (excluding motor parameters) 2: Erase Records	0	○	
F0.25	Personalized Menu Display Options	Units: Quick Menu Display Options 0: Do Not Display 1: Display Tens: Options of Non-Factory Value Menu Display 0: Do Not Display 1: Display	00	●	
F0.26	Function Modification Property	0: Modifiable 1: Non-Modifiable	0	●	

F1: Motor Parameters					
F1.01	Rated Power of Motor	0.1kW~1000.0kW	Model Confirmed	○	
F1.02	Rated Voltage of Motor	1V~2000V	Model Confirmed	○	
F1.03	Rated Current of Motor	0.01A~655.35A (Motor Drive Power<=55kW) 0.1A~6553.5A (Motor Drive Power>55kW)	Model Confirmed	○	
F1.04	Rated Frequency of Motor	0.01Hz~Maximum Frequency	Model Confirmed	○	
F1.05	Rated Rotating Speed of Motor	1rpm~65535rpm	Model Confirmed	○	

F1.06	Stator Resistance of Motor	0.001Ω~65.535Ω (Motor Drive Power≤55kW)	Harmonic Parameter	○	
F1.06	Stator Resistance of Motor	0.0001Ω~6.5535Ω (Motor Drive Power>55kW)	Harmonic Parameter	○	
F1.07	Rotor Resistance of Motor	0.001Ω~65.535Ω (Motor Drive Power≤55kW) 0.0001Ω~6.5535Ω (Motor Drive Power>55kW)	Harmonic Parameter	○	
F1.08	Leakage Inductance of Motor	0.01mH~655.35mH (Motor Drive Power≤55kW) 0.001mH~65.535mH (Motor Drive Power>55kW)	Harmonic Parameter	○	
F1.09	Mutual Inductance of Motor	0.1mH~6553.5mH (Motor Drive Power≤55kW) 0.01mH~655.35mH (Motor Drive Power>55kW)	Harmonic Parameter	○	
F1.10	No Load Current of Motor	0.01A~A1.03 (Motor Drive Power≤55kW) 0.1A~A1.03 (Motor Drive Power>55kW)	Harmonic Parameter	○	
F1.37	Parameter Self-Identification of Motor	0: No Operation 1: Static Identification 2: Complete Identification	0	○	

F2: Input Terminal

F2.00	X1 Terminal Function Options	0: No Function	1	○	
F2.01	X2 Terminal Function Options	1: Forward Running (FWD)	2	○	
F2.02	X3 Terminal Function Options	2: Reverse Running (REV)	9	○	
F2.03	X4 Terminal Function Options	3: Three-Wire Control 4: Jog Forward (FJOG)	0	○	
F2.04	X5 Terminal Function Options	5: Jog Reverse (RJOG) 8: Free Stopping 9: Faults Reset	0	○	
F2.10	X Terminal Filter Time	0.000s~1.000s	0.010s	●	
F2.35	X1 Delay Time	0.0s~3600.0s	0.0s	○	
F2.36	X2 Delay Time	0.0s~3600.0s	0.0s	○	
F2.37	X3 Delay Time	0.0s~3600.0s	0.0s	○	
F2.38	X Terminal Valid Mode Options	0: High Level Effective 1: Low Level Effective Units: X1 Tens: X2 Hundreds: X3 Thousands: X4 Ten Thousands: X5	00000	○	

F4: Auxiliary Parameters

F4.00	Jog Operation Frequency	0.00Hz~Maximum Frequency	2.00Hz	●	
F4.01	Jog Acceleration Time	0.0s~6500.0s	20.0s	●	
F4.02	Jog Deceleration Time	0.0s~6500.0s	20.0s	●	
F4.16	Default Power-On Time	0h~65000h	0h	●	
F4.17	Default Operation Time	0h~65000h	0h	●	

F4.42	Timer Options	0: Invalid 1: Valid	0	●	
F4.43	Options of Timer For Operation Time	0: F4.44 Setting 1: AI1 2: AI2 3: AI3 (Keyboard Potentiometer) Simulated input range corresponds to F4.44	0	●	
F4.44	Timer For Operation Time	0.0Min~6500.0Min	0.0Min	●	
F4.47	Modules Temperature	0°C~100°C	75°C	●	
F4.53	Current Setting of Operation Time	0.0Min~6500.0Min	0.0Min	●	

F8: Keypad and Display Parameters

F8.07	Radiator Temperature of the Inverter Module	0.0°C~100.0°C		◇	
F8.09	Total Operation Time	0h~65535h		◇	
F8.13	Total Power-On Time	0h~65535h		◇	
F8.14	Total Power Consumption	0~65535 KWh		◇	

F9: Errors and Protection Parameters

F9.00	Motor Overload Protection Options	0: Prohibit 1: Allow	1	●	
F9.01	Motor Overload Protection Gain	0.20~10.00	1.00	●	
F9.02	Motor Overload Warning System	50%~100%	80%	●	
F9.03	Overvoltage Stall Gain	0~100	0	●	
F9.04	Overvoltage Stall Voltage Protection	120%~150%	130%	●	
F9.05	Overcurrent Stall Gain	0~100	20	●	
F9.06	Overcurrent Stall Current Protection	100%~200%	150%	●	
F9.07	Power -On Ground Fault Protection Options	0: Invalid 1: Valid	1	●	
F9.09	Number of Times of Faults Auto-Reset	0~20	0	●	
F9.11	Time Interval of Faults Auto-Reset	0.1s~100.0s	1.0s	●	
F9.12	Input Phase Loss/Contactor Pull-In Protection Options	Units: Input Phase Loss Protection Tens: Contactor Pull-In Protection 0: Prohibit 1: Allow	11	●	
F9.13	Output Phase Loss Protection Options	0: Prohibit 1: Allow	1	●	
F9.14	First Time Error Type	0: No Error 1: Preserve 2: Accelerated Overcurrent 3: Decelerated Overcurrent 4: Constant Speed Overcurrent 5: Accelerated Overvoltage 6: Decelerated Overvoltage	—	◇	

F9.15	Second Time Error Type	7: Constant Speed Overvoltage 8: Snubber Resistor Overload 9: Under Voltage 10: Motor Drive Overload 11: Motor Overload 12: Input Phase Loss 13: Output Phase Loss	—	◇	
F9.16	Third Time (Most recent one) Error Type	14: Overheated Module 16: Communication Error 17: Contactor Error 18: Current Detection Error 21: Parameter Read and Write Error 22: Motor Drive Hardware Error 23: Motor Ground Fault 29: Power-On Times Up 30: Offload 40: Fast Current-Limit Overtime 62: Breaking Current Too Small	—	◇	
F9.17	Third Time (Most recent one) Error: Frequency	—	—	◇	
F9.18	Third Time (Most recent one) Error: Current	—	—	◇	
F9.19	Third Time (Most recent one) Error: Bus Frequency	—	—	◇	
F9.20	Third Time (Most recent one) Error: Input Terminal Status	—	—	◇	
F9.21	Third Time (Most recent one) Error: Motor Drive Temperature	—	—	◇	
F9.22	Third Time (Most recent one) Error: Motor Drive Status	—	—	◇	
F9.23	Third Time (Most recent one) Error: Power-On Time	—	—	◇	
F9.24	Third Time (Most recent one) Error: Operation Time	—	—	◇	
F9.27	Second Time Error: Frequency	—	—	◇	
F9.28	Second Time Error: Current	—	—	◇	
F9.29	Second Time Error: Bus Voltage	—	—	◇	
F9.30	Second Time Error: Input Terminal Status	—	—	◇	
F9.31	Second Time Error: Motor Drive Temperature	—	—	◇	
F9.32	Second Time Error: Motor Drive Status	—	—	◇	
F9.33	Second Time Error: Power-On Time	—	—	◇	
F9.34	Second Time Error: Operation Time	—	—	◇	
F9.37	First Time Error: Frequency	—	—	◇	
F9.38	First Time Error: Current	—	—	◇	
F9.39	First Time Error: Bus Voltage	—	—	◇	

F9.40	First Time Error: Input Terminal Status	—	—	◇	
F9.41	First Time Error: Motor Drive Temperature	—	—	◇	
F9.42	First Time Error: Motor Drive Status	—	—	◇	
F9.43	First Time Error: Power-On Time	—	—	◇	
F9.44	First Time Error: Operation Time	—	—	◇	

Function Codes	Name	Minimum Unit
H0: Basic Observation Parameters		
H0.00	Operation Frequency (Hz)	0.01Hz
H0.01	Set Frequency (Hz)	0.01Hz
H0.02	Output Current (A)	0.01A
H0.03	Output Voltage (V)	1V
H0.04	Output Power (kW)	0.1kW
H0.05	Output Torque (%)	0.1%
H0.06	Bus Voltage (V)	0.1V
H0.07	X Input Status 1	1
H0.12	AI3 (Keyboard Potentiometer Voltage) (V)	0.01V
H0.24	Current Power -On Time	1Min
H0.25	Current Operation Time	0.1Min
H0.26	Motor Overload Count	0.1%
H0.27	Motor Current Percent	0.1%
H0.28	Remaining Operation Time	0.1Min
H0.34	Motor Drive Overload Count	0.1%
H0.35	Motor Drive Current Percent	0.1%

4.2 Special Function

Function Codes	Code Name	Range of Settings	Factory Value	Property	Setting Value
Group FP					
Fp.00	Operation Frequency at Low Speed	0%~100% Set Frequency=Maximum Frequency* Fp.00	50%	○	
Fp.01	Operation Frequency at High Speed	0%~100% Set Frequency=Maximum Frequency* Fp.01	100%	○	
Fp.02	Operation Frequency of Operating Box	0%~100% Set Frequency=Maximum Frequency* Fp.02	30%	○	
Fp.03	Brake Control Options	1: No Brake Logic 2: Construction Elevator Brake Logic	2	○	
Fp.05	Brake Release Current	0%~200%	100%	○	
Fp.11	Direction of Torque Reaction	0-1 0: Same as the operation direction 1: Opposite operation direction	1	○	
Fp.12	Forward Opening Gate Frequency	0Hz~10.00Hz	2.00Hz	○	
Fp.13	Forward Brake Frequency	0Hz~10.00Hz	2.00Hz	○	
Fp.14	Reverse Opening Gate Frequency	0Hz~10.00Hz	2.00Hz	○	
Fp.15	Reverse Brake Frequency	0Hz~10.00Hz	2.00Hz	○	
Fp.16	Delay Before Forward Opening Gate	0.00s~10.00s	0.20s	○	
Fp.17	Delay After Forward Opening Gate	0.00s~10.00s	0.10s	○	
Fp.18	Delay Before Forward Brake	0.00s~10.00s	0.00s	○	
Fp.19	Delay After Forward Brake	0.00s~10.00s	0.50s	○	
Fp.20	Delay Before Reverse Opening Gate	0.00s~10.00s	0.20s	○	
Fp.21	Delay After Reverse Opening Gate	0.00s~10.00s	0.10s	○	
Fp.22	Delay Before Reverse Brake	0.00s~10.00s	0.00s	○	
Fp.23	Delay After Reverse Brake	0.00s~10.00s	0.30s	○	
Fp.27	Opening Gate Current Detection	0%~200% 0%: Do Not Detect	100%	○	

Group B0					
B0.00	Reserve	—	—	◇	
B0.01	Startup Latency of Going Up at Power Frequency	0.00s~10.00s	1.00s	○	
B0.02	Shutdown Latency of Going Up at Power Frequency	0.00s~10.00s	1.00s	○	
B0.03	Startup Latency of Going Down at Power Frequency	0.00s~10.00s	1.00s	○	
B0.04	Shutdown Latency of Going Down at Power Frequency	0.00s~10.00s	1.00s	○	
B0.05	Limit Switch Filtering Time	0.000s~10.000s	0.020s	○	
B0.06	Button Filtering Time	0.000s~10.000s	0.020s	○	
B0.07	Output Filtering Time	0.000s~10.000s	0.020s	○	

B0.08	Voice Control	Units: Volume Control 0~7 Tens: Chinese/English Language Switch 0: Chinese 1: English	07	○	
B0.09	Reserve	—	—	◇	
B0.10-19	Reserve	—	—	◇	
B0.20	Clock Password1	0~65535	-	○	
B0.21	Clock Password2	0~65535	-	○	
B0.22	Clock Password3	0~65535	-	○	
B0.23	Calibration Password	0~65535	-	○	
B0.24	Calibration Time - Year	2000~2099	-	○	
B0.25	Calibration Time - Date	1.01~12.31	-	○	
B0.26	Calibration Time - Hour and Minute	0~23.59	-	○	
B0.27	Max Time - Year	2000~2099	2089	○	
B0.28	Max Time - Date	1.01~12.31	12.23	○	
B0.29	Max Time - Hour and Minute	0~23.59	8.00	○	
B0.30	Weighing Alert Enabling	0: Weighing Function OFF 1: Weighing Function ON	1	○	
B0.31	Cage Weight Calibration Options	0: No Operation 1: Empty Cage Calibration 2: Weighing Calibration	0	○	
B0.32	Cage Weight Standard	0~10000	800Kg	○	
B0.33	Standard Human Weight Measured by Cage	0~1000	70Kg	○	
B0.34	Weighing Calibration Weight	1~10000	2000Kg	○	
B0.35	Weighing Constant	50.0~300.0%	100.0%	○	
B0.36	Rated Carrying Capacity	1~10000	2000Kg	○	
B0.37	Weighing Display Constant	20.0~300.0%	100.0%	○	
B0.38	Weighing Alert Constant	20.0~300.0%	100.0%	○	
B0.39	Reserve for Weighing	—	—	○	
B0.40 -B0.51	Reserve	—	—	◇	
B0.52	Weighing Display Reset	0.00~655.35T	—	◇	
B0.53	Reserve	—	—	◇	
B0.54	Current Time - Year	2000~2099	—	◇	
B0.55	Current Time - Date	1.01~12.31	—	◇	
B0.56	Current Time - Hour and Minute	0~23.59	—	◇	
B0.57	Total Operation Time	0~65535	—	◇	
B0.58- B0.60	Reserve	—	—	◇	
B0.61- B0.65	Reserve	—	—	◇	
B0.66	Weighing Alert 0 - Year	2000~2099	—	◇	
B0.67	Weighing Alert 0 - Date	1.01~12.31	—	◇	

B0.68	Weighing Alert 0 - Hours and Minutes	0~23.59	—	◇	
B0.69	Weighing Alert 0 - Weight	0~9.99	—	◇	
B0.70	Weighing Alert 1 - Date	1.01~12.31	—	◇	
B0.71	Weighing Alert 1 - Hours and Minutes	0~23.59	—	◇	
B0.72	Weighing Alert 1 - Weight	0~9.99	—	◇	
B0.73	Weighing Alert 2 - Date	1.01~12.31	—	◇	
B0.74	Weighing Alert 2 - Hours and Minutes	0~23.59	—	◇	
B0.75	Weighing Alert 2 - Weight	0~9.99	—	◇	
B0.76	Weighing Alert 3 - Date	1.01~12.31	—	◇	
B0.77	Weighing Alert 3 - Hours and Minutes	0~23.59	—	◇	
B0.78	Weighing Alert 3 - Weight	0~9.99	—	◇	
B0.79	Weighing Alert 4 - Date	1.01~12.31	—	◇	
B0.80	Weighing Alert 4 - Hours and Minutes	0~23.59	—	◇	
B0.81	Weighing Alert 4 - Weight	0~9.99	—	◇	
B0.82	Weighing Alert 5 - Date	1.01~12.31	—	◇	
B0.83	Weighing Alert 5 - Hours and Minutes	0~23.59	—	◇	
B0.84	Weighing Alert 5 - Weight	0~9.99	—	◇	
B0.85	Weighing Alert 6 - Date	1.01~12.31	—	◇	
B0.86	Weighing Alert 6 - Hours and Minutes	0~23.59	—	◇	
B0.87	Weighing Alert 6 - Weight	0~9.99	—	◇	
B0.88	Weighing Alert 7 - Date	1.01~12.31	—	◇	
B0.89	Weighing Alert 7 - Hours and Minutes	0~23.59	—	◇	
B0.90	Weighing Alert 7 - Weight	0~9.99	—	◇	
B0.91- B0.99	Reserve	—	—	◇	

Chapter 5 Maintenance and Troubleshooting

5.1 Daily Maintenance and Inspection

5.1.1 Daily Maintenance

Due to the effect of ambient temperature, humidity, dust and vibration, motor drive's components age over time, leading to potential errors or shorter life of the motor drive. Therefore, it is necessary to perform maintenance on the motor drive on daily basis. Below is the list of daily inspection:

- 1) if the motor drive makes unusual sound while running;
- 2) if the motor vibrates while running;
- 3) if the installation environment have changes;
- 4) if the cooling fans are working properly;
- 5) if the motor drive is overheated.

Daily Cleaning:

- 6) Keep the motor drive clean;
- 7) Clean the dust on the surface of motor drive, keeping them, especially the metal particles, from going inside motor drive;
- 8) Clean the greasy dirt on the cooling fans.

5.1.2 Periodic Inspection

Please inspect the places that is hard to spot. Below is the list of places that need to inspect periodically:

- 1) Inspect the vents and clean them regularly;
- 2) Check loose screws;
- 3) Check if the motor drive corrodes;
- 4) Check if there are any arc marks on terminals
- 5) Main Circuit Insulation Test

Note: Disconnect the motor drive and main circuit when measuring insulation resistance using a megohmmeter (DC 500V Megohmmeter). Do not test the control circuit insulation using an insulation resistance meter. No need to perform High Voltage Test since it has been done before leaving the factory

5.1.3 Wear and Tear Parts Change

Motor drive's wear and tear parts include cooling fans and electrolytic capacitor for filtering, and their life is closely related to ambient conditions and maintenance. Below are their life span:

Cooling Fans: 2-3 years

Electrolytic Capacitor: 4-5 years

Note: Standard life span is only valid under the conditions below. User may determine when to change parts according to their realistic situation.

- Ambient Temperature: Annual average temperature is around 30℃.
- Duty Cycle: Less than 80%
- Operating Rate: Less than 20 hours per day

1) Cool Fans

Possible Damage Reasons: Worn bearings and aged fan blades

Criteria: if fan blades have cracks; if there is an unusual vibration sound at start-up

2) Electrolytic Capacitor for Filtering

Possible Damage Reasons: Bad Input Power Supply, High Ambient Temperature, Frequent Load Jump, and Aged Electrolytes.

Criteria: If there is a leakage of liquid, If there is a bulge on safety valve, test of electrostatic capacitance, and test of insulation resistance.

5.1.4 Storage for Motor Drive

A few notes that users need to know if they plan to store the motor drive for a long or short period:

- 1) Put the product in the original package when storing it.
- 2) Long period of storage may result in the deterioration of electrolyte capacitance. Therefore, it is necessary to power it on in 2 years and have it stay on for at least 5 hours. Input voltage must slowly rise to the set value using a voltage regulator.

5.2 Warranty

- 1) Warranty may only be used for this motor drive itself.
- 2) This Limited Warranty covers any defects in material or workmanship under normal use during the 18-month Warranty Period (please refer to the bar code on the product for the manufacture date) at no charge. After the Warranty Period, a reasonable charge will be applied.
- 3) During the Warranty Period, the following actions will result in a charge:
 - a) User does not follow the instruction manual and causes damage to the product;
 - b) Damage caused by fire, flood and abnormal voltage;
 - c) Damage caused by using the product improperly.
- 4) Any charge is subject to the company's standard. If an agreement is made, the agreement is prioritized.

5.3 Fault Alarm and Solutions

If JS500 Series Construction Elevator All-in-One Device malfunctions during operation, the motor drive will immediately stop to protect motor. At same time, the motor drive's SPST starts working as well. The motor drive panel will display fault codes, and the corresponding error types and common solutions are shown below. The following examples are only for reference. Please do not repair or disassemble the product on your own. If you can not solve the errors, please reach out to the company or product agencies for tech support.

Error Type	Operation Panel Display	Troubleshooting	Solutions
Accelerated Overcurrent	Err02	<ol style="list-style-type: none"> 1. Motor drive's output circuit is grounded or short; 2. Control mode is vector and no parameters identification; 3. Acceleration time is too short; 4. Voltage is too low; 5. Initiate start on the motor while it is still running; 6. Sudden load added while accelerating; 7. The model of motor drive is too small; 8. The braking resistor is short. 	<ol style="list-style-type: none"> 1. Eliminate the peripheral failure; 2. Initiate the identification of motor parameters; 3. Increase acceleration time; 4. Adjust the voltage to the normal range; 5. Choose rotational speed tracking start or start it after the motor stops; 6. Cancel the sudden load addition; 7. Use the motor drive that has a higher power level; 8. Check if the braking resistance is normal
Decelerated Overcurrent	Err03	<ol style="list-style-type: none"> 1. Motor drive's output circuit is grounded or short; 2. Control mode is vector and no parameters identification; 3. Deceleration time is too short. 4. Voltage is too low; 5. Sudden load added while decelerating; 6. No braking units or braking resistors added 7. The braking resistor is short. 	<ol style="list-style-type: none"> 1. Eliminate the peripheral failure; 2. Initiate the identification of motor parameters; 3. Increase deceleration time; 4. Adjust the voltage to the normal range; 5. Choose rotational speed tracking start or start it after the motor stops; 6. Cancel the sudden load addition; 7. Check if the braking resistance is normal.
Constant Speed Overcurrent	Err04	<ol style="list-style-type: none"> 1. Motor drive's output circuit is grounded or short; 2. Control mode is vector and no parameters identification; 3. Voltage is too low; 4. Sudden load added during operation; 	<ol style="list-style-type: none"> 1. Eliminate the peripheral failure; 2. Initiate the identification of motor parameters; 3. Adjust the voltage to the normal range; 4. Choose rotational speed tracking start or start it after the motor stops; 5. Cancel the sudden load addition;

		<ol style="list-style-type: none"> The model of motor drive is too small; The braking resistor is short. 	<ol style="list-style-type: none"> Use the motor drive that has a higher power level; Check if the braking resistance is normal.
Accelerated Overvoltage	Err05	<ol style="list-style-type: none"> Input voltage is too high; An external force drags the motor during acceleration; Acceleration time is too short; No braking units or braking resistors added 	<ol style="list-style-type: none"> Adjust the voltage to the normal range; Remove the external force or add braking resistors; Increase acceleration time; Add braking units and braking resistors.
Decelerated Overvoltage	Err06	<ol style="list-style-type: none"> Input voltage is too high; An external force drags the motor during deceleration; Deceleration time is too short; No braking units or braking resistors added 	<ol style="list-style-type: none"> Adjust the voltage to the normal range; Remove the external force or add braking resistors; Increase deceleration time; Add braking units and braking resistors.
Constant Speed Overvoltage	Err07	<ol style="list-style-type: none"> Input voltage is too high; An external force drags the motor during deceleration; 	<ol style="list-style-type: none"> Adjust the voltage to the normal range; Remove the external force or add braking resistors;
Power Supply Failure	Err08	<ol style="list-style-type: none"> Input voltage is not within the range of regulation. 	<ol style="list-style-type: none"> Adjust input voltage to the range of regulation.
Undervoltage Failure	Err09	<ol style="list-style-type: none"> Sudden power outages; Input voltage of the motor drive is not within the range of regulation; Unusual bus voltage; Bridge rectifiers and snubber resistor malfunctions; Drive board malfunctions; Control board malfunctions. 	<ol style="list-style-type: none"> Fault reset; Adjust the voltage to the normal range; Contact tech support; Contact tech support; Contact tech support; Contact tech support;
Motor Drive Overload	Err10	<ol style="list-style-type: none"> Excessive load or motor stalling; The model of motor drive is too small. 	<ol style="list-style-type: none"> Reduce load and inspect the motor and mechanical conditions; Use the motor drive that has a higher power level.
Motor Overload	Err11	<ol style="list-style-type: none"> Check if F9.01: motor protection parameter is appropriately set; Excessive load or motor stalling; The model of motor drive is too small. 	<ol style="list-style-type: none"> Set the parameter correctly; Reduce load and inspect the motor and mechanical conditions; Use the motor drive that has a higher power level.
Input Phase Loss	Err12	<ol style="list-style-type: none"> Abnormal three-phase input power; Drive board malfunctions; Lightening protection board malfunctions; Main control board malfunctions 	<ol style="list-style-type: none"> Check and eliminate the problems in the peripheral circuit; Contact tech support; Contact tech support; Contact tech support.
Output Phase Loss	Err13	<ol style="list-style-type: none"> Abnormal wiring from motor drive to motor; Unbalanced three-phase output of motor drive when motor operates; Drive board malfunctions; Modules malfunction. 	<ol style="list-style-type: none"> Eliminate peripheral errors; Inspect three-phase winding and eliminate errors; Contact tech support; Contact tech support.

Modules Overheated	Err14	<ol style="list-style-type: none"> 1. Ambient temperature is too high; 2. Clogged vents; 3. Broken fans; 4. Broken thermistor modules; 5. Broken inverter module; 	<ol style="list-style-type: none"> 1. Lower ambient temperature; 2. Clean the vents; 3. Change the fans; 4. Change the thermistor modules; 5. Change the inverter modules.
Communication Failure	Err16	<ol style="list-style-type: none"> 1. Host computer malfunctions; 2. communication wires malfunction; 3. Incorrect setting of FD group of communication parameters. 	<ol style="list-style-type: none"> 1. Check the wiring of host computer; 2. Check the wiring of communication; 3. Correctly set the communication parameters.
Contactors Failure	Err17	<ol style="list-style-type: none"> 1. Drive board and power malfunction; 2. Contactors malfunction. 	<ol style="list-style-type: none"> 1. Change the drive board or power board 2. Change the contactors.
Current Detection Failure	Err18	<ol style="list-style-type: none"> 1. Check hall devices; 2. Check drive board. 	<ol style="list-style-type: none"> 1. Change the hall devices; 2. Change the drive board.
EEPROM Read and Write Failure	Err21	<ol style="list-style-type: none"> 1. Damaged EEPROM Chip 	<ol style="list-style-type: none"> 1. Change the main control board.
Motor Drive Hardware Malfunctions	Err22	<ol style="list-style-type: none"> 1. Overvoltage; 2. Overcurrent. 	<ol style="list-style-type: none"> 1. Deal it as overvoltage error; 2. Deal it as overcurrent error.
Ground Fault Errors	Err23	<ol style="list-style-type: none"> 1. Ground fault of the motor 	<ol style="list-style-type: none"> 1. Change electric cables or motors.
Reach the set total power-on time	Err29	<ol style="list-style-type: none"> 1. Accumulated power-on time (F8.13) reaches the set value (F4.16). 	<ol style="list-style-type: none"> 1. Clean the records using the initiation of parameters.
Offload Errors	Err30	<ol style="list-style-type: none"> 1. Operation current of motor drive is smaller than F9.64. 	<ol style="list-style-type: none"> 1. Confirm the removal of load or if parameters setting of F9.64 and F9.65 matches real situation.
CBC Errors	Err40	<ol style="list-style-type: none"> 1. Excessive load or motor stalling; 2. The model of motor drive is too small. 	<ol style="list-style-type: none"> 1. Reduce load and inspect the motor and mechanical conditions; 2. Use the motor drive that has a higher power level.
Reduced Opening Gate Current	Err62	<ol style="list-style-type: none"> 1. Improper setting of motor parameters; 2. Disconnected motor wires. 	<ol style="list-style-type: none"> 1. Modify motor parameters; 2. Reconnect wires.

5.4 Common Errors and Solutions

Order No.	Error Types	Possible Reasons	Solutions
1	No Display With Power On	No power grid voltage or voltage is too low; Broken power switch on the drive board; Broken bridge rectifiers; Broken snubber resistors of motor drive; Broken control board and keypad; Control board is disconnected to drive board and keypad;	Inspect input power; Check bus voltage; Unplug and plug the wires on pin 8 and pin 28; Contact tech support;
2	Garbled Codes On the Display	Bad connection between drive board and control board; Damaged parts on control board; Short motor or motor cables ground fault; Hall errors; Power grid voltage too low;	Unplug and plug the wires on pin 8 and pin 28; Contact tech support;
3	“Err23” Alert on the Display	Short motor or motor cables ground fault; Broken motor drive;	Measure the insulation of the motor and the output cable using a megohmmeter; Contact tech support;
4	Frequent “Err14” Module Overheated Alert	The setting of carrier frequency is too high; Broken fans or clogged vents; Internal damaged parts of motor drive (Thermocouple, etc.);	Lower the carrier frequency (F0.15); Change fans, and clean the vents; Contact tech support
5	Motor Does Not Work After Starting The Motor Drive	Motor and motor cables; Incorrect motor drive parameters setting (Motor parameters); Bad connection between drive board and control board; Drive board malfunctions	Check the connection between motor drive and motor; Change the motor or eliminate mechanic errors; Check and reset the motor parameters;
6	X Terminal Failure	;Parameter setting errors ;External signal errors; PLC and loose +24V jump wire; Control board errors;	Check and reset group F2 parameters; Reconnect external signal wires; Reconfirm PLC and +24V jump wire; Contact tech support;
8	Frequent Error Reports of Overcurrent and Overvoltage By Motor Drive	Incorrect motor parameters setting; Inappropriate Acceleration/Deceleration Time Load Fluctuation	Reset motor parameters or tune the motor; Set a proper acceleration/deceleration time Contact tech support
9	Err17 Alert	Soft-starter does not pull in;	Check if there are the loose wires on the contactor; Check if the contactor malfunctions; Check if 24V power supply can normally power the contactor. Contact tech support;
10	Display “8.8.8.8.8.”	Damaged parts on the control board;	Change the control board;

Chapter 6 Accessories Model Recommendation

6.1 Braking Resistor Model Recommendation

The following table represents the recommended data sheet for different models of braking resistors, user may choose different resistance and power of the braking resistors based on realistic situation (Note: resistance of braking resistors must not be smaller than the recommended value in the table while power may be higher), the choice of braking resistors is determined by the power of motor in realistic application system, which is closely related to system inertia, deceleration time, and energy of potential load, etc. The larger the inertia of system is, the shorter the deceleration time is. Similarly, frequent braking requires braking resistors to have higher power and smaller resistance.

Motor Drive Model	Recommended Power For Braking Resistors	Recommended Resistance For Braking Resistors	Braking Unit
JS500-**-037B	≥19KW	≥12Ω	Built-in, Rated Current75A
JS500-**-045B	≥23 KW	≥10Ω	Built-in, Rated Current90A
JS500-**-055B	≥28 kW	≥8Ω	Built-in, Rated Current110A
JS500-**-075B	≥38 kW	≥6Ω	Built-in, Rated Current150A

Dimensions of Braking Resistors

BZR-15/24kW-S1 Diagram

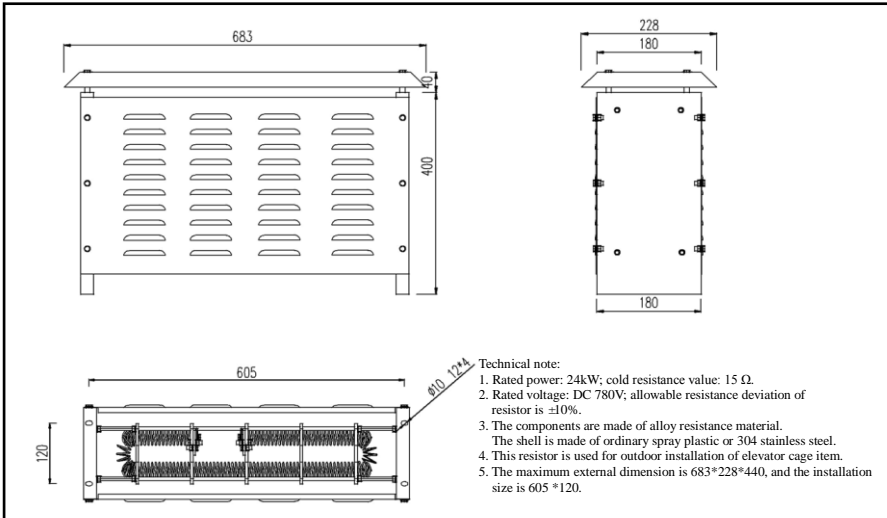

BZR-10/36kW-S1 Diagram

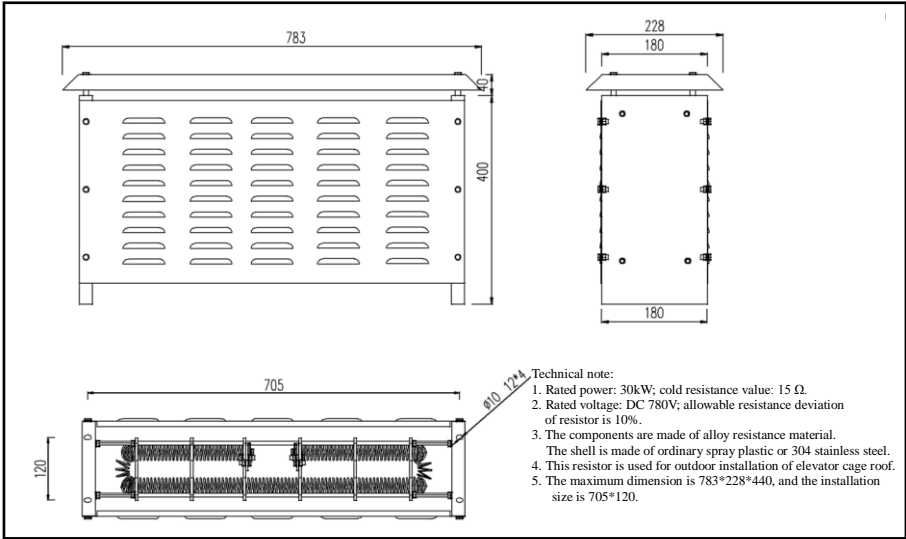

6.2 Specs and Dimensions of the In-Cage Operation Panel

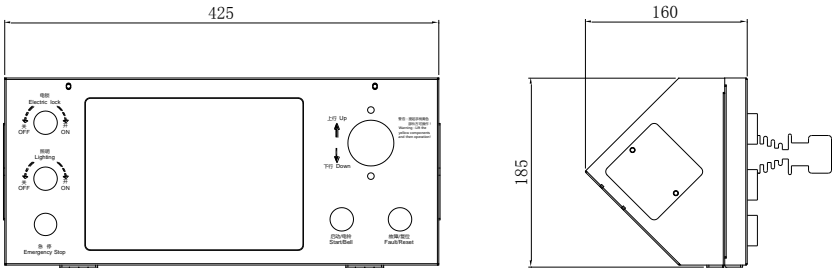

6.3 Specs of Load Pin Sensors

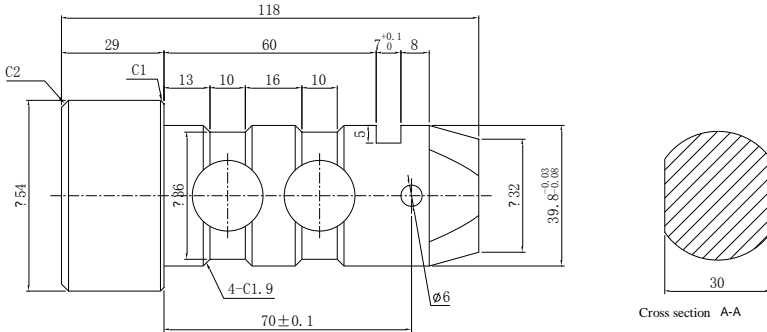

Product Model	IN-XZ40-3t
Synthetic Error	±0.5% F.S
Safe Overload	150% F.S
Input Impedance	420Ω±20Ω
Output Impedance	352Ω±5Ω
Temperature Range	-30℃~70℃
IP Ratings	IP67
Max Bridge Voltage	10-15V
Output Sensitivity	1±0.05mV/V

6.4 Rooftop Control Box/Drop Test Box

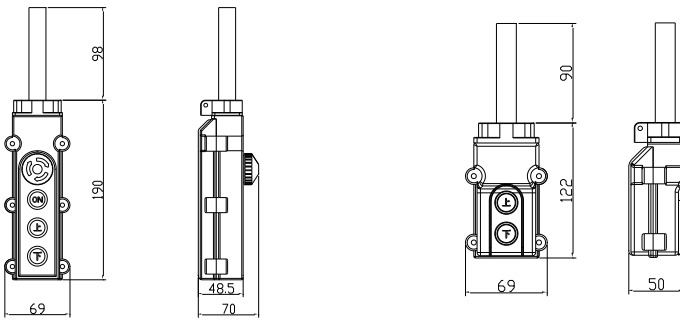

6.5 Model Selection of Encoders and Installation Instructions

1. A flexible coupling is required to connect motor and encoder during the installation process, forming a flexible connection to avoid encoder damage caused by rigid connection.
2. The shafts of encoder and motor is expected to have good concentricity. There should not have extrusion or bending after coupling is installed. There should not have cam or axial shifting.
3. Cables of the encoder must be shielded twisted pair signal cables. Each pair of differential signaling requires twisted pair cables. Installing the signal cables should not be interrupted. If you need to extend the cable, it is necessary to guarantee the continuity of shielded connection and connect the signal extension cables by welding.
4. Shielded wires of the encoder need grounded on both sides. Single grounded side will only resist the interference of low frequency while it does not resist high frequency. Use the elimination method to test the uncertain interference in the field.

Appendix A Instruction Manual

1. Inspection Sheet Before Operation

- ① Check if the motor wires, braking resistors and PCL are short or damaged;
- ② Check if limit switch and indicators are working properly;
- ③ Check if all of the electrical interlock devices (Skylight window, electric lock, and emergency stop, etc.) are still effective;

3. Operation Notes

- ① It is prohibited to directly do loaded test run on the elevator (No load test run→lightly loaded test run→Fully loaded test run);
- ② If the direction of the elevator is incorrect, for example, it goes up but it is ordered to go down, switching any two motor wires may solve the problem (Caution: Main power must be turned off before switching the wires);
- ③ Immediately stop and inspect the elevator if any fault occurs. Only start the elevator after faults are eliminated;
- ④ Start Conditions: No emergency stop signal, door check is in place, press “START” button and the elevator is starting;
- ⑤ Operating Conditions: While under the starting status, only satisfy all limit switches before pushing “handle” to have the elevator operate properly;
- ⑥ High-Speed Operating Conditions: Need to satisfy “Up and Down Deceleration Limit” and “Master Acceleration” signals;
- ⑦ Drop Test Conditions: In normal mode, long press fault reset button and start button for 10 seconds to enter drop test mode. Error indicator stays on and voice reminder of drop test mode is constantly playing. Now the drop test box is allowed to operate. In drop test mode, long press fault reset button and start button for 10 seconds to enter normal mode;
- ⑧ Out-Cage Operation Conditions: Enter out-cage operation mode after connecting the out-cage operation box. Now the operation panel cannot be used but emergency stop is still effective. Operation panel returns to normal after disconnecting the out-cage operation box.

3. Weighing Function:

Weighing Calibration Steps:

- ① Only one calibration personnel is allowed to be in the elevator. Set the weight of the calibration personnel in function code B0.33;
- ② Long press empty-cage calibration button for 3 seconds or set B0.31 to 1, the device will initiate empty-cage calibration. After finishing calibration, there will be a buzzing reminder and B0.31 is automatically set to 0. Empty-cage standard will be saved at B0.32;
- ③ Weighing Constant Calibration: Add some weight to the cage (suggested rated load: 2000Kg). Set load weight at the function code B0.34. Set B0.31 to 2 in order to initiate weighing constant calibration and B0.31 will be automatically set to 0 afterwards. The weighing constant will be saved at B0.35. If tested weight satisfies error requirements, weighing constant calibration will not be allowed;
- ④ Rated Load: Modify rated load of the construction elevator through B0.36;
- ⑤ After finishing weighing calibration, you can observe if the weigh value matches the actual value by increasing/decreasing weight. If they match, the calibration is a success. To do a weighing warning test and a weighing alert test, increase the load to the set values respectively.

Appendix B Bolts Tightening Torque

Listed torque values in this table only apply to bolts tightening on the connecting terminal of our company’s products.
(g=10N/kg)

Model	Bolt Specs	Tightening Torque (N.m)	Tightening Torque (kgf.cm)	Tightening Torque (lbf.in)
JS500-A1-037B	M5	2.4	24	21.3
JS500-A1-037B	M6	3.0	30	26.6
JS500-B1-037B	M5	2.4	24	21.3
JS500-B1-037B	M6	3.0	30	26.6